

INSTALLATION INSTRUCTIONS

FOR THE RADIA PROFESSIONAL SPEAKER Pro-**ME LINE SOURCE LOUDSPEAKER

1. Introduction

The Pro-**ME Line source system is a high-end professional in-wall or in-ceiling system that incorporates a high performance planar line source transducer and extruded aluminum rear enclosure. The metal enclosure provides extremely reliable protection of the system and surrounding environment from any possible hazards as well as from transmitting sound from transducer to building structure and adjacent rooms.

The Pro-**ME Line has four models with different length: Pro-1.9ME, Pro-1.3ME, Pro-1.0ME and Pro-0.7ME. The number indicates the length of a driver element in inches. The Pro-Line drivers used in the Pro-**ME Line source systems are special in that they do not have the wave guide used in the standard models. This allows for a better match with half space in-wall acoustical loading.

The standard shipping package consists of:

- complete Pro**ME unit ready to install
- paint masking plug to protect the driver during painting
- cardboard template for marking drywall cutout borders
- packaging box
- this manual

- Add on option: ZNC 70/100/130/190 new construction metal bracket facilitates installation process and provides reliable mounting when the system is installed during construction

ProME Line source system is a special and unique device. It possesses several features that allow extremely transparent, high quality reproduction with utmost intelligibility at very large distances. In order to achieve the best results please read these instructions carefully prior to installation.**

We also encourage you to read a white paper about ribbon technology and line source systems at <http://www.bgcorp.com>. This will help you to fully understand and successfully utilize all advantages of the Pro-**ME system.

2. Positioning the Pro-******ME Line system.

You should decide where to position the system for the best results prior to installation. The Pro-******ME Line system provides very wide 120° dispersion in the horizontal plane, hence allowing for wide and even horizontal coverage. This gives you significant flexibility when choosing the mounting spot in horizontal plane. At the same time it is very important to position the Pro-******ME Line system appropriately in the vertical plane.

Vertical dispersion is limited to a 10° angle (5° above top loudspeaker end line and 5° below loudspeaker bottom end line).

Fig1. Depicts Pro-******ME Line system coverage. Make sure that in any event (rising seats, standing or sitting position) the audience ear level falls within the region between the borders outlining the dispersion angle. The same rules apply to in-ceiling installation, where unique Pro-******ME line properties can be successfully utilized.

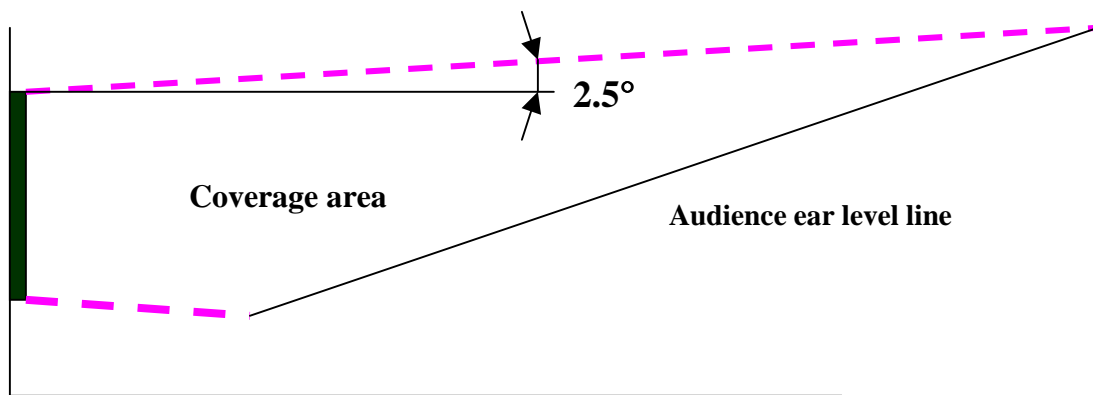

Fig.1 Pro-****ME Line Coverage**



2. New construction drywall installation

You should install ZNC new construction bracket prior to drywall installation.

ZNC bracket allows mounting of Pro-******ME system between studs with up to 22" on-center dimension.

Figure 2

Drill a stud at the bottom and pull the speaker wiring into the designated stud cavity (with or without metal conduit). Mount the installation bracket between studs in the desired location.



Figure 3

The designated stud cavity should be considered as SC – sound cavity. A speaker system installed into a wall generates substantial sound energy that is transmitted to adjacent structure. It is highly recommended to use extra means during drywall installation in order to avoid structural vibrations, noise, rattling and other phenomenon that substantially reduce quality of reproduction. Use extra screws and/or glue or appropriate compound between drywall and studs to insure tight and continuous contact. Apply glue on the bracket as well so that it bonds to drywall, creating additional drywall reinforcement.

After drywall is installed, the ZNC metal bracket will serve as a guide for a speaker cutout so that the speaker can easily slip into the space and be mounted. ZNC bracket also adds additional strength to the "dog/ cam toggle" mounting points.

Figure 4

Fill the cavity with sound and vibration absorptive material before Pro-**ME Line installation. Stiff foam pads that fill the whole cavity to the sides from the speaker opening will work the best. Place foam in such a way that it is tightly squeezed between drywall panels. Use adhesive if necessary to secure the foam pads. You may place a thin pad on the opposite wall in front of the speaker opening, so that when speaker is installed, this pad would be slightly compressed. It is recommended to put extra foam on the sides so that it has a tight contact with the speaker enclosure as well.

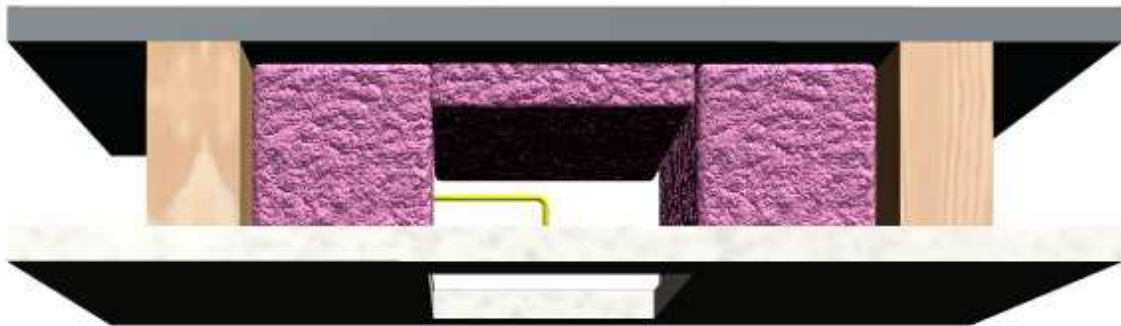

You should also decide how you want to paint the system. You can paint it either on the floor prior to installation or installed in the wall. The speaker grille should be removed and painted separately from the speaker. Remove plastic end caps. Remove the grille. Insert print masking plug (included) instead of the speaker grille during painting to protect the driver. Use masking tape to protect adjacent wall when painting the installed speaker. Painted grille should not have holes clogged with paint and must remain acoustically transparent. Do not reinstall the grille into the speaker at this time.

The Pro-******ME Line system has 7/8" diameter opening at the bottom to accommodate any conduit fitting of your choice. If you don't use a wire conduit, you may install a standard plastic grommet in the hole to secure speaker wire connection.

Place the speaker on a firm support near the cutout. Connect wire to the speaker paying attention to proper polarity. White wire represents "+" or positive end and gray wire serves as a "ground" or negative end.

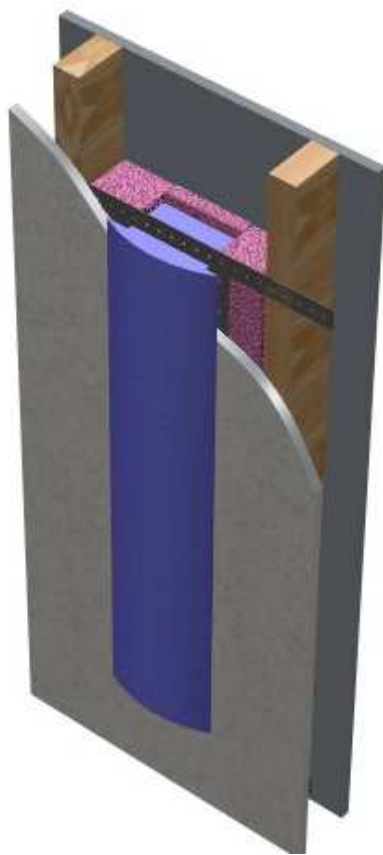

Figure 5

Place the speaker into the cutout. Remove masking paint plug. Remove rubber strips on each side from the driver. The dog/cam toggle mounting clamps are driven with machine screws located under the rubber. Using a screwdriver or power tool carefully tighten each clamp. Make sure that drywall is tightly "sandwiched" between the clamps and speaker frame.

Reinstall the grille. Start at the top and work the grille into the bracket by carefully squeezing it between the outer flanges. Insert both end caps.

3. Retrofit drywall installation

If you need to retrofit the Pro-******ME speaker into drywall of existing construction, follow the same steps, except that you do not install ZNC bracket.

Instead you need to use a cardboard template for marking drywall cutout borders (included). Position the template against the wall in the desired location. Mark the cutout. After drywall has been cut, repeat the same steps starting from Fig.4.

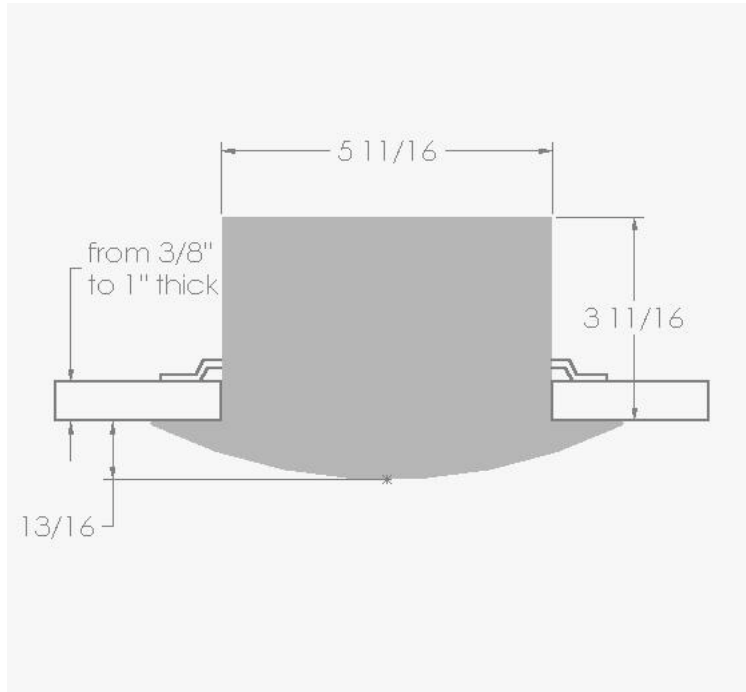

Figure 6

Top view (profile) of the Pro-**ME Line loudspeaker mounted in a wall/ceiling.

The same technique should be used for in-ceiling installation. In this case absorptive material may be omitted.

4. CROSSOVER and EQ REQUIREMENTS FOR THE Pro-ME LINE TRANSDUCERS

The Pro-**ME Line transducers are extremely robust devices, with the largest models able to handle as much as 1.5 kilowatts of peak power,

but they are by nature “displacement limited”, meaning that long excursions at low frequencies are to be avoided. This will require proper crossover selection and setup, and will ensure maximum performance and minimum distortion.

The Pro-**ME Line requires at least 150 Hz 18dB/octave (or 24dB/octave) high-pass crossover to protect the speaker from excessive excursion at low frequencies. Active or passive crossovers can be used.

The Pro-**ME Line transducer also requires a notch filter. A passive notch filter and 150Hz hi-pass filter is available from Radia Professional Speakers, please order the Pro-**XO "add on" item and specify transducer model number. The Pro-**XO will be installed in the Pro-**ME system at the factory.

Cutout Dimensions

Cutout width dimensions for all four drivers is 5.66”

Pro-0.7ME length cutout dimension is 29.375”

Pro-1.0ME length cutout dimension is 40.995”

Pro-1.3ME length cutout dimension is 52.495”

Pro-1.9ME length cutout dimension is 76.625”